

Methodology and Software for Estimating Target Efficiency of Land Remote Sensing Satellites at the Stage of Design

V.I. Kurenkov¹, A.S. Kucherov¹

¹Samara National Research University, Moskovskoe Shosse 34A, Samara, Russia, 443086

Abstract. The paper aims to present the software developed with the purpose of estimating land remote sensing satellites and space monitoring system target efficiency indices. The essence of the approach is step-by-step simulation of the satellite orbital motion with permanent determination of the flight conditions and estimation of the satellite and the space monitoring system target parameters. Main factors affecting target efficiency are taken into consideration; they include orbital elements and the satellite coordinates variation while its orbital movement, the satellite manoeuvres in the process of its target operation, conditions of survey objects taking, characteristics of survey equipment, etc. The algorithm used is based on a number of mathematical models such as models for generating initial data on survey objects, models for choice of survey objects within the satellite swath, models for constructing LRSS survey path, models for estimating orientation of solar cell battery panels, etc. The software has been developed in Delphi programming support environment. It enables calculation of LRSS target parameters such as ground resolution, operational efficiency, surveillance frequency, productivity.

1. Introduction

In the process of land remote sensing satellites (LRSS) design, especially at its initial stages, their design parameters and conceptual design are changed permanently. The reason is that mass-dimensional, power, orbital and target parameters of a space monitoring system are interrelated. These parameters need to be adjusted and required values of target characteristics of the system must be reached indisputably. Now, in construction offices, the parameters adjustment is fulfilled in the process of a large number of iterations. During this process the spacecraft project is considered in various departments specialized in different aspects of spacecraft designing, such as target characteristics, power, ballistics, thermal processes, reliability, etc. Such an approach takes a lot of time and resources.

The problem can be solved with the help of the software giving the possibility of online verifying the effect of the spacecraft design parameters change on the space monitoring system target characteristics. There exist approaches and software for estimating some particular efficiency indices of LRSS and space monitoring systems [1-6] but we have not succeeded in finding out such approaches for complex estimating all target efficiency indices with account for full range of affecting factors.

This paper aims to present the software developed with the purpose of estimating LRSS and space monitoring system target efficiency indices considering parameters of target equipment, spacecraft ballistic structure, ground information receiving centres, etc.

2. The approach

The essence of the approach is step-by-step simulation of the spacecraft orbital motion with permanent determination of the flight conditions and, with their consideration, plugging-in specific software modules for estimating the spacecraft and the space monitoring system target parameters.

3. Factors considered

The following factors were taken into account:

- orbital elements and LRSS coordinates variation while its orbital movement factoring in the orbit precession and the perigee argument deviation;
- LRSS manoeuvres in the process of LRSS target operation;
- conditions of survey objects (SO) taking;
- typical actigrams of spacecraft on-board systems operation;
- characteristics of survey equipment;
- limitations on angular velocity and acceleration of LRSS rotation;
- limitations concerning LRSS power balance;
- location of survey objects and ground information receiving centres, etc.

4. Mathematical models

The software is based on the algorithm using the following mathematical models.

4.1. Models for LRSS orbital parameters estimation

The main models of this group were borrowed [4] and adopted. Osculating orbital elements with regard for the first-order secular perturbations are calculated with fixed time step size.

4.2. Models for generating initial data on survey objects

Initial data include:

- the list of prospective survey objects with their coordinates;
- array of survey objects with coordinates uniformly distributed over the Earth surface (it is formed with the help of pseudorandom-number generator).

4.3. Models for determining the fact of survey object visibility

In order to verify the fact of the survey object being within the LRSS field of view (FW), relative motion of the satellite and the object is simulated. The FW radius AD (Fig. 1) depends upon the Earth radius R_E , the satellite orbit altitude H and the maximum deflection angle of electro-optical telescopic system (EOTS) γ [2, 5, 6]:

$$AD = AO \cdot \sin \alpha = R_E \sin \alpha,$$

where angle α may be found as

$$\alpha = \arcsin \left[\frac{H}{H + R_E} \cdot \frac{\operatorname{tg} \gamma}{\sqrt{1 + (\operatorname{tg} \gamma)^2}} \right] - \arccos \left[\frac{1}{\sqrt{1 + (\operatorname{tg} \gamma)^2}} \right].$$

The condition of survey object being inside FV (Fig. 2) looks as follows:

$$\arccos[\sin \varphi_s \cdot \sin \varphi_o + \cos \varphi_s \cdot \cos \varphi_o \cdot \cos(\lambda_s - \lambda_o)] < \alpha,$$

where $\varphi_s, \lambda_s, \varphi_o, \lambda_o$ are geographical coordinates of subsatellite point and survey object.

4.4. Models for estimation of LRSS productivity

These models include [5]:

- models for estimating statistical parameters of flow of survey objects entering the satellite swath;
- models for estimating the LRSS dynamic characteristics;

- models for estimating the number of taken survey objects factoring in the LRSS dynamic characteristics;
- models for estimating the LRSS productivity using simulation approach.

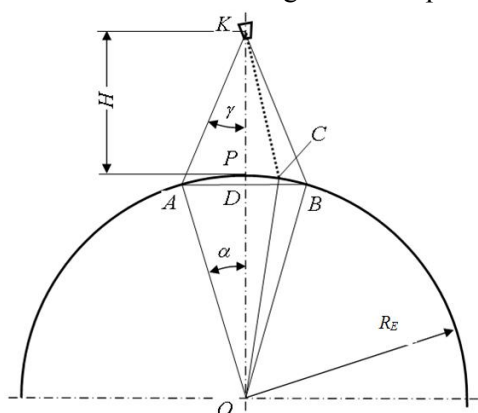

Figure 1. The scheme for determination of the field of view radius.

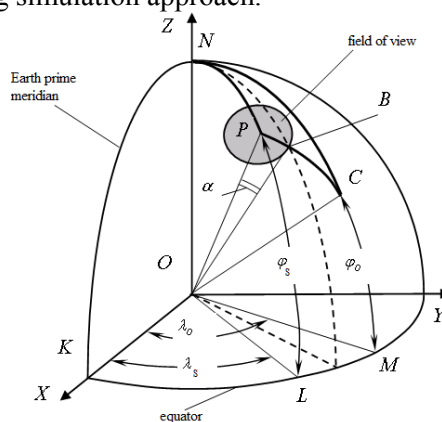

Figure 2. The scheme for determining the fact of the survey object being inside FW.

4.5. Models for estimating conditions of survey objects taking

Conditions of survey objects taking are essential to planning LRSS manoeuvres: satellite retargeting from one survey object at another, star tracking, Sun-pointing, etc. The conditions taken into account are as follows:

- LRSS being in the Earth shadow;
- LRSS being within the light spot;
- the Sun angle value being sufficient for the survey object taking;
- mutual disposition of LRSS and data relay satellite;
- mutual disposition of LRSS and navigation satellites.

Appropriate mathematical models have been developed.

4.6. Models for estimation of EOTS ground resolution and capture width

EOTS ground resolution and capture width are among the main target efficiency indices. Taking into account only geometric factors, ground resolution ΔL may be found as follows (Fig. 3):

$$\Delta L = \frac{\delta \cdot L}{f} \cos \vartheta (1 + tg^2 \gamma + tg^2 \vartheta),$$

where δ is liner dimension of elementary fotodetector (pixel), L is range to the survey object

$$L = (R_E + H) \cos \mu \pm \sqrt{(R_E + H)^2 \cos^2 \mu - H(2R_E + H)},$$

f is EOTS focal length, ϑ , γ are respectively pitch and roll angles, R_E is the Earth radius, H is the satellite orbit altitude, μ is deflection angle of EOTS axis deviation from nadir.

$$\mu = \arcsin \left(\frac{\sqrt{tg^2 \gamma + tg^2 \vartheta}}{\sqrt{1 + tg^2 \gamma + tg^2 \vartheta}} \right).$$

EOTS capture width is

$$B = \frac{b \cdot L}{f} \cos \vartheta (1 + tg^2 \gamma + tg^2 \vartheta),$$

where b is length of CCD array.

proportional to cubed diameter of primary mirror while the model proposed in paper [10] assumes fourth power of the diameter. Papers [11, 12] propose methodology of developing regression models based on cluster analysis.

4.8. LRSS solid model

The special graphic editor has been designed (see Fig. 4) in order to simulate spacecraft of simplified shapes. In contrast to stereotype CAD-systems, this editor gives the possibility of embedding models and algorithms especially developed for solving the problem under discussion.

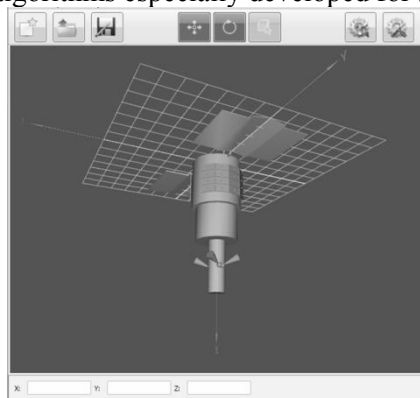

Figure 4. The piece of graphic editor window.

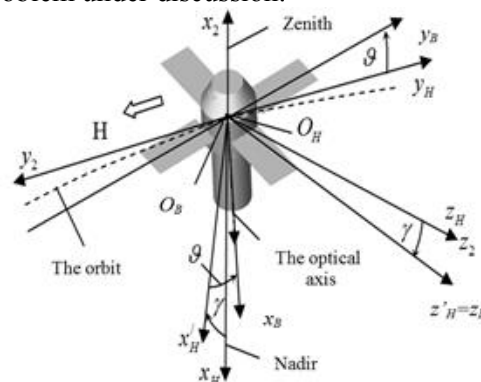

Figure 5. The scheme for estimating LRSS spatial orientation.

4.9. Models for determining LRSS spatial orientation

These models include:

- models for simulating the satellite target rotations for randomly chosen survey objects;
- models for determining the satellite spatial orientation in the process of standard survey paths implementation.

Fig. 5 represents the scheme used for calculation of the satellite roll and pitch angles. Appropriate algorithms for optical reconnaissance satellites and radar reconnaissance satellites have been developed.

4.10. Models for determination of LRSS operational efficiency

There exist some various indices of operational efficiency. Here operational efficiency is treated as an interval between the moment of any object survey and the moment when the object picture may be send to the ground receiving centre (GRC). The last operation is possible when the satellite is within the radio coverage zone (RCZ) of the ground receiving centre. Fig.6 represents the earth section by the plane passing through the earth centre O, satellite K, and ground receiving centre P. R_E is the earth radius, H is the satellite orbit altitude. Point E of the satellite orbit lies on the GRC sky line. It is the boundary point of the orbit from which the satellite can communicate with the GRC. It may be seen that the central angle α of the radio coverage zone

$$\alpha = \arccos\left(\frac{R_E}{R_E + H}\right).$$

Hence, the condition of the satellite being inside RCZ looks as follows:

$$\arccos[\sin \phi_S \cdot \sin \phi_P + \cos \phi_S \cdot \cos \phi_P \cdot \cos(\lambda_S - \lambda_P)] < \alpha,$$

where $\phi_S, \lambda_S, \phi_P, \lambda_P$ are geographical coordinates of the GRS and LRSS respectively.

4.11. Models for estimation of LRSS power balance

Models of this group include:

- models for estimating cosine of the angle between solar cell battery planes and the Sun line (so called alpha angle cosine) considering the satellite target operation and cell battery planes

shielding. The models take into account the orbit precession, the Earth yearly movement around the Sun and the satellite target rotations.

- models for estimation of a storage battery charge;
- models for estimating electricity power consumed from the battery.

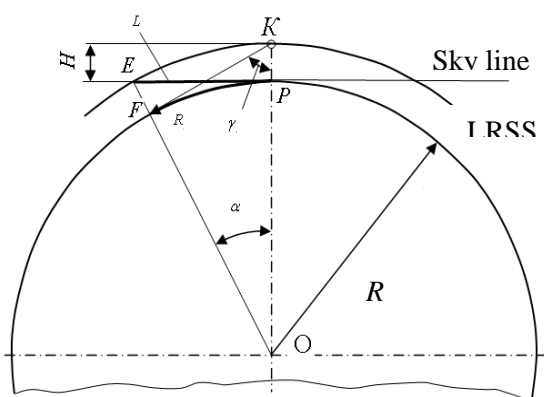

Figure 6. Radio coverage zone dimension.

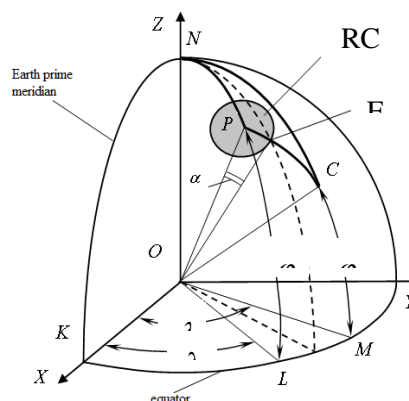

Figure 7. Determination of a LRSS being inside the RCZ.

4.12. Models for estimation of LRSS lifetime

Lifetime is one of the main LRSS characteristic. It depends upon the satellite reliability and its resources the most critical of which is the propellant margin. It is consumed in the process of the orbit correction and desaturation of gyrodynes. Models for estimation of necessary mass and volume of complex propulsion unit may be found in paper [14].

5. The software features

The software has been developed in Delphi programming support environment. The software allows including additional units in order to extend the number of considered parameters and aspects. The software enables calculation of LRSS target parameters such as ground resolution, operational efficiency, surveillance frequency, productivity. As an example of some intermediate outcomes obtained with the help of the software, in Fig. 8 the satellite trace and its zones of visibility are shown. Boundaries of the satellite zones of visibility are calculated at given interval of time. Fig. 9 represents distribution function of periodicity index calculated for the following given data: the satellite orbit altitude $H=729$ km; the orbit inclination $i=98,3^\circ$; maximum deflection angle of electro-optical telescopic system $\gamma = 45^\circ$. Stepped configuration of the functions is caused with partition of statistical data in the process of their handling. Fig. 10 shows distribution function of operational efficiency; geographical coordinates of the ground receiving centre and those of the test survey object respectively are: $\phi_p = 53^\circ, \lambda_p = 50^\circ, \phi_o = 80^\circ, \lambda_o = 100^\circ$.

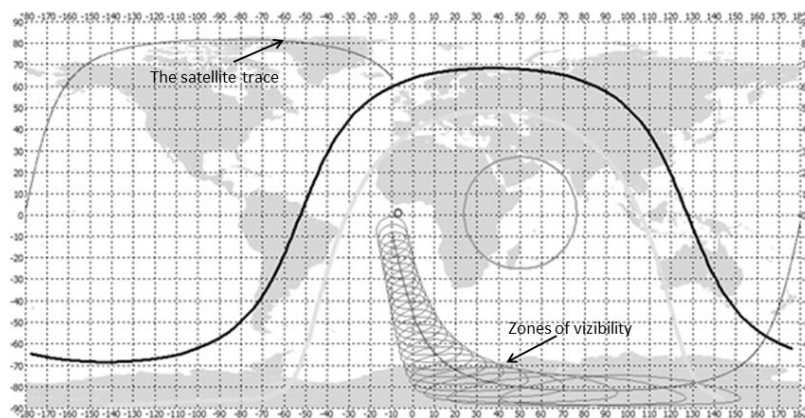

Figure 8. The satellite trace and its zones of visibility.

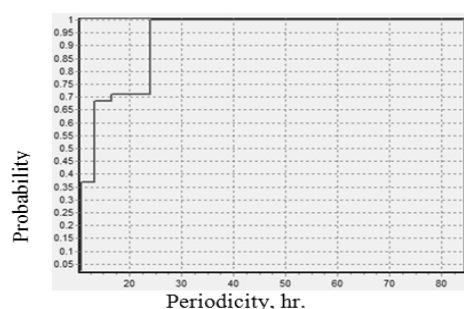

Figure 9. Distribution function of periodicity index.

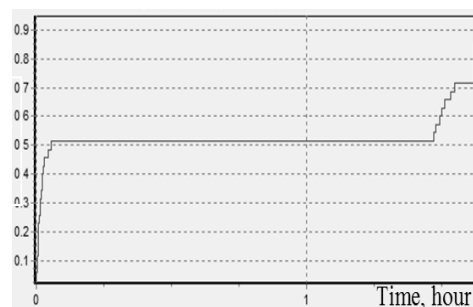

Figure 10. Distribution function of operational efficiency index.

6. Conclusion

Methodology and software for online estimating target efficiency indices of land remote sensing satellites and space monitoring systems have been developed. Open structure of the software allows plugging-in additional software modules without changing master program file. The software was verified at sufficient number of cases. Comparison of the results obtained with those known from the practice of real land remote sensing satellites exploitation proved adequacy of developed models and algorithms.

7. References

- [1] Hantceverov, F.R. Simulating space systems of land natural resources reconnaissance / F.R. Hantceverov, V.V. Ostrouhov. – Moscow: Mashinostroenie publishing house, 1989. – 264p.
- [2] Gonin, G.B. Space survey of the Earth / G.B. Gonin. – Leningrad: Nedra publishing house, 1989. – 252 p.
- [3] Malyshev, V.V. Satellite monitoring systems. Analysis, synthesis, and control / V.V. Malyshev, M.N. Krasil'shchikov, O.P. Nesterenko. – Moscow: MAI publishing house, 2000. – 568 p.
- [4] Sollogub, A.V. Systems of land remote sensing spacecraft: mathematical models of spacecraft efficiency upgrading / A.V. Sollogub, G.P. Anshakov, V.V. Danilov. – Moscow: Mashinostroenie publishing house, 1993. – 368 p.
- [5] Kurenkov, V.I. Basic principles of spacecraft constructions and simulation of target operation / V.I. Kurenkov, V.V. Salmin, B.A. Abramov. – Samara: Samara State Aerospace University publishing house, 2006. – 296 p.
- [6] Kurenkov, V.I. Simulation of monitoring spacecraft target operation with regard for power balance / V.I. Kurenkov, V.V. Salmin, B.A. Abramov. – Samara: Samara State Aerospace University publishing house, 2007. – 160 p.
- [7] Malamed, E.R. Designing of space-based telescopes / E.R. Malamed. – St. Petersburg: ITMO University publishing house, 2002. – 291 p.
- [8] Kurenkov, V.I. Methodology of choosing main design objectives of survey satellites / V.I. Kurenkov, V.V. Salmin, A.G. Prokhorov. – Samara: Samara State Aerospace University publishing house, 2007. – 160 p.
- [9] Sentcov, Yu.I. LRSS weight dependent upon ground resolution of survey equipment / Yu.I. Sentcov, M.V. Hmelyshikov. – Vestnik NPO im. S.A. Lavochkina. – 2015. – Vol. 2(28). – P. 81-88.
- [10] Baklanov, A.I. Capability of upgrading the space complex based on spacecraft "AIST-2" / A.I. Baklanov, M.V. Klyushnikov // Proceedings of the IV All-Russian scientific conference "Recent problems in rocket and space technology". – Samara: Publishing house of SNTs RAN. – 2015. – P. 303-309.
- [11] Kurenkov, V.I. Developing statistical models of satellites onboard systems masses based on cluster analysis / V.I. Kurenkov, A.S. Kucherov, A.A. Yakischik. – Samara: Publishing house of SNTs RAN. – 2018. – Vol. 20(1). – P. 46-63.
- [12] Kurenkov, V.I. Use of Cluster Analysis for Development of Star Tracker Mass Statistical Model / V.I. Kurenkov, A.S. Kucherov // Procedia Engineering. – 2017. – Vol. 185. – P. 227-230.

- [13] Kurenkov, V.I. Models for Estimation of Land Remote Sensing Satellites Operational Efficiency / V.I.Kurenkov, A.S.Kucherov // AIP Conference Proceedings. – 2016. – Vol.1798. – P. 020085.
- [14] Kurenkov, V.I. Estimation of mass-dimensional characteristics of a complex propulsion unit of Earth remote sensing spacecraft / V.I. Kurenkov, A.S. Kucherov, A.A. Yakischik // Vestnik SGAU. – 2014. – Vol. 5(47). – P. 46-53.